

# Surface Mount LEDs

1210 Type e 3.2mm(L) X 2.7mm(W) X 1.1mm(H)

IF=20mA Ta=25°C

Device No	Color		Wavelength (nm)		VF Typical (V)	Brightness ( mcd)		View Angle 2θW
	Emitter	Lens	λp	λd		Minimum	Typical	
HCL-155D/G	orange	white diffused	625	618	2.05	4.0	8.0	140
	yellow green		570	567	2.15	3.2	9.5	
HCL-155Y/YG	yellow	white diffused	589	585	2.10	3.0	6.5	
	yellow green		570	567	2.15	3.2	9.5	

1210 Lens 1.8mm Type e 3.2mm(L) X 2.5mm(W) X 1.5mm(H)

IF=20mA Ta=25°C

Device No	Color		Wavelength (nm)		VF Typical (V)	Brightness ( mcd)		View Angle 2θW
	Emitter	Lens	λp	λd		Minimum	Typical	
HCL-156UR/G	super red	water clear	660	643	1.80	24.0	45.0	20
	yellow green		570	567	2.15	15.0	26.0	

Dimension:

Unit : mm. Tolerance:0.2mm.

## HCL-155XX Series

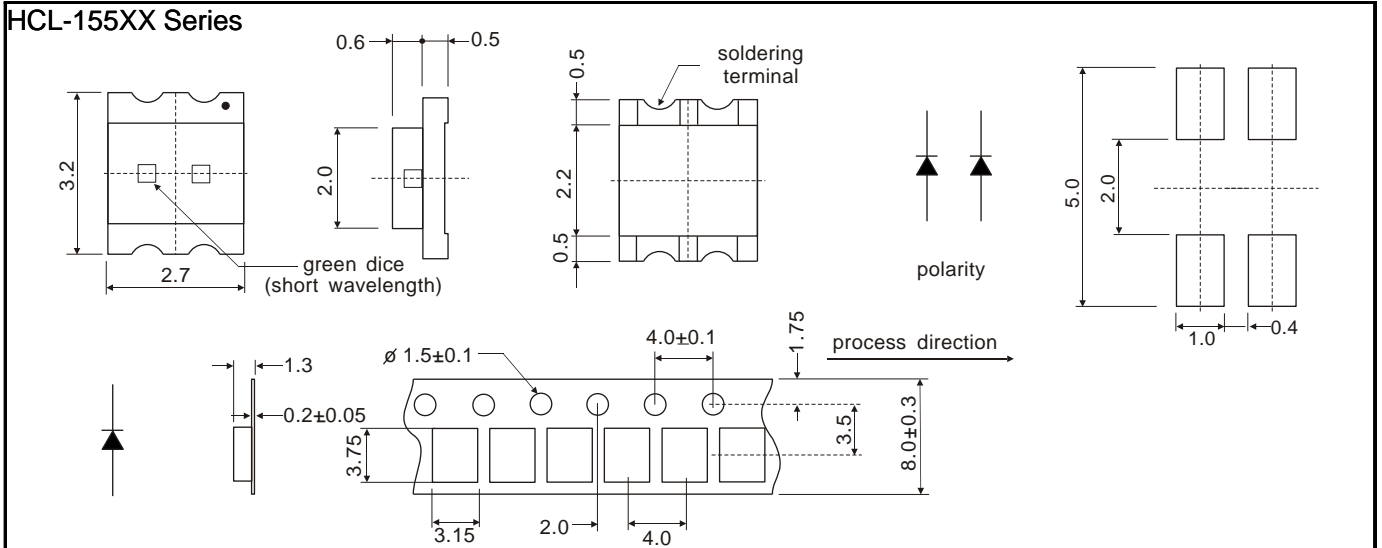

## HCL-156XX Series

