

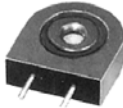



PIEZO TRANSDUCERS

EXTERNAL DRIVE TYPE

Model Number	ELT137	ELT167	ELT520	ELT812
Resonant Frequency (± 500 Hz)	2,800	4,000	6,000	4,000
Operating Voltage (Vp-p maximum)	30	25	30	30
Sound Pressure Level at 10cm/5V square wave (dB, minimum)	100 at 2.8 KHz	80 at 4.0 KHz	90 at 6.0 KHz	92 at 4.0 KHz
Current Consumption (mA, maximum)	9	7	8	11
Capacitance ($\pm 30\%$ PF)	22,000	14,000	12,000	25,000
Operating Temperature ($^{\circ}\text{C}$)	-20~+60	-20~+80	-20~+60	-20~+80
Storage Temperature ($^{\circ}\text{C}$)	-30~+70	-30~+90	-30~+70	-30~+90
Weight (Gram)	11.3	0.9	4	2.5
Shape				
Dimension Unit: mm Tolerance: $\pm 0.5\text{mm}$	